

CE Class I Medical Device, compliant with the Medical device directive 93/42/EEC

Warning

The information contained in this manual is subject to change without notice.

The Diagrams are inserted only for reference and may vary slightly from the actual device.

Spencer Italia S.r.l. assumes no responsibility for any errors contained herein or for damage, accidents or consequences connected with the supply, performance or use of this manual.

First edition: 10/03/2016
Rev.2 31/08/2020



INDEX

1. MODELS	3
2. INTENDED USE	3
3. REFERENCE STANDARD	3
4. INTRODUCTION	3
4.1 USE OF THE MANUAL	3
4.2 LABELLING AND TRACKING CONTROL OF THE DEVICE	3
4.3 SYMBOLS	4
4.4 WARRANTY AND SUPPORT	4
5. WARNINGS	4
6. SPECIFIC WARNINGS	6
6.1 PHYSICAL REQUIREMENTS OF OPERATORS	7
7. RESIDUAL RISK	7
8. TECHNICAL DATA AND COMPONENTS	7
9. START UP	7
10. FUNCTIONAL CHARACTERISTICS	8
11. INSTRUCTIONS FOR USE	8
11.1 MEDICAL VEHICLE REQUIREMENTS	8
11.2 INSTALLATION	8
11.3 USE OF THE FASTENER	10
12. CLEANING AND MAINTENANCE	10
12.1 CLEANING	10
12.2 PRECAUTIONARY MAINTENANCE	10
12.3 PERIODIC MAINTENANCE	11
12.4 SPECIAL SERVICING	11
12.5 LIFE SPAN	11
13. TROUBLESHOOTING	12
14. ACCESSORIES	13
15. SPARE PARTS	13
16. DISPOSAL	13

Warning

The information contained in this document could be modified without any warning and is not to be intended as a commitment on behalf of Spencer Italia S.r.l. Spencer products are exported to many countries and the same identical regulations are not always valid. For this reason there could be differences between the description here described and the product actually delivered. Spencer continually strives to reach the perfection of all items sold. We therefore hope you will understand if we reserve the right, at any time, to modify the shape, equipment, lay-out or technical aspects that are herein described.

© Copyright Spencer Italia S.r.l.

All rights reserved. No part of this document can be photocopied, reproduced or translated into another language without the written approval of Spencer Italia S.r.l.

1. MODELS

The following standard models can undergo change, revision and implementation without any notice.

- S-MAX 10G FASTENER FOR STRETCHER

2. INTENDED USE

S-MAX is a fastener for Spencer stretchers to be permanently installed within ambulances. Its purpose is to hold the stretcher in accordance with the requirements of the EN 1789 standard.

The patient should not intervene on the device.

3. REFERENCE STANDARD

As a distributor or end user of products manufactured and/or marketed by Spencer Italia S.r.l. you are strictly required to have basic knowledge of any legal requirements applying to the devices contained in this supply that are in power in the goods final destination Country (including laws and norms regarding technical specifications and/or safety requirements) and therefore you are strictly required to have the necessary knowledge to guarantee all aspects regarding the total conformity of the products to the regulations in the relevant territory.

REFERENCE	DOCUMENT TITLE
UNI EN 1789 § 4.5.9 - § 5.4.2 - § 5.4.5	Medical vehicles and their equipment - Road ambulances

4. INTRODUCTION

4.1 USE OF THE MANUAL

This manual is intended to provide the health care operator with the all the necessary information for its safe and appropriate use as well as adequate maintenance of the device.

Note: The manual is an integral part of the device. It must be kept for the duration of the device and must accompany the device in case of change of ownership or destination. If the operating instructions received relate to products not received, you must immediately contact the manufacturer before use.

The Spencer product manuals can be downloaded from the website or can be requested by <http://support.spencer.it> or by contacting the manufacturer. Exceptions are items whose essentiality for reasonable and predictable use is such as to make it unnecessary to prepare instructions in addition to the following warnings and directions on the label.

Regardless of the level of experience gained in the past with similar devices, it is recommended that you carefully read this manual before installing, operating or using the product or any maintenance

4.2 LABELLING AND TRACKING CONTROL OF THE DEVICE





Each device has got an identification label positioned on the device itself and/or on its box, which includes identification data about the manufacturer, the product, the CE mark, the serial number (SN) or lot number (LOT).

It must never be removed or covered.

In case of damage or loss, request a duplicate from the manufacturer. Failure to do so will interrupt the validity of the guarantee as the device can no longer be traced.

The Directive 93/42/EEC requires manufacturers and distributors of medical devices to keep track of the device location. If the device was in a different location to the address where it was sent or to where it had been sold, donated, lost, stolen, exported, or destroyed, permanently removed from use, or if the device had not been delivered directly from Spencer Italia S.r.l., register your device at <http://service.spencer.it> or inform the customer (see § 4.4).

4.3 SYMBOLS

Symbols	Meaning
	General or specific warnings
	See instructions for use
	Product code
	Serial Number
	The product is compliant with the requirements of Directive 93/42/EEC

4.4 WARRANTY AND SUPPORT

Spencer Italia S.r.l. guarantees that products are without defects for a period of **one year from the date of purchase**.

For any information regarding the correct interpretation of the instruction manual, the use, maintenance, installation and restore of the product, contact the Spencer customer care service ph. +39.0521.541111, fax +39.0521.541222, e-mail service@spencer.it, or visit <http://it.spencer.it/contatti> to find the nearest service centre for assistance.

In order to facilitate the assistance service, please always indicate the lot number (LOT) or serial number (SN) shown on the label applied on the box or on the device.

Conditions for warranty and assistance can be viewed on <http://support.spencer.it>.

Note: Record and store; these instructions, lot (LOT) or serial number (SN) if any, date and place of purchase, date of first use, date servicing, user names and comments.

5. WARNINGS

The warnings, notes and other important safety information are indicated in this section and are clearly visible throughout the entire manual.

User training

Note: Laboratory testing, post production tests, instruction manuals cannot always consider every possible scenario for use. This means that in some cases the performance of the product could be notable different from results to date obtained. Instructions are continually being updated and are under tight surveillance of fully qualified staff with adequate technical formation.

- Regardless of the level of experience gained previously with similar devices, it is recommended that you carefully read this manual before installing, operating or using the product or carrying out any maintenance. If in doubt, contact Spencer Italia S.r.l. to obtain the necessary clarifications.
- The product must be used by trained personnel only, having attended specific training for this device and not for similar products.
- The suitability of the user to use the product may be attested by the records of training, where the names of those trained, of the trainers, dates and place are indicated. **This register which certifies the eligibility of the operators to use the Spencer device must be kept for a period of 10 years after the disposal of the device itself. This register will be made available to the competent Authorities and/or manufacturer if requested. In the absence of such documentation, sanctions will be applied.**
- Do not allow any untrained person to help during the use of the device, because they could cause damage to the patient or to themselves.
- The product should be operated only by personnel trained in the use of this product and not in others similar.

Note: Spencer Italia S.r.l. is always at your disposal to organise product training.

Installers training

The installation of the device must be carried out only by qualified and trained staff authorized by Spencer Italia S.r.l. Dates and procedures for participating in training courses will be arranged between the customer and our Commercial offices.

Product functionality

Use of the device in anyway other than described in this manual is forbidden.

- Before each use the perfect operating state of the device must be thoroughly checked as specified in the instruction manual. If any damage or abnormalities which could in any way influence the correct functioning and the safety of the device are detected, the device must be immediately removed from service and the manufacturer must be contacted.
- If any failure or incorrect functioning of the device is detected, it must be immediately substituted with a similar item so that the rescue procedures are guaranteed without any interruption.
- The appliance must not in any way be tampered with (modification, adjustment, addition, replacement). In such cases all responsibility for any malfunctions or injuries caused by the appliance itself will be denied; moreover CE certification and product warranty will be considered void.
- Those who modify or have modified, prepare or have prepared medical appliances in such a way that they no longer serve the purpose for which they were intended, or no longer supply the intended service, must satisfy the valid conditions for the introduction onto the market.
- During use, position and adjust the device taking care not to cause any obstruction to rescuers and or any other rescue equipment.
- Ensure that all the necessary precautions are taken in order to avoid the hazards that can arise as the result of contact with blood or body fluids, when applicable.
- **The warranty seals, where present, must not be removed;** in such case, the manufacturer will no longer recognize the product warranty and will accept no responsibility in case of incorrect operation or damage caused by the product itself.
- Avoid contact with sharp objects.
- The installation of the device must be carried out only by qualified and trained staff authorized by Spencer Italia S.r.l. Timing and procedures for conducting training courses shall be agreed between the customer and our Commercial offices.
- Operating temperature: from -10°C to + 40°C

Storage

- The device should not be exposed to or come into contact with any source of combustion or inflammable agents. Store in a cool, dry, dark place and do not expose to direct sun.
- Do not store the device underneath any heavy objects which could cause structural damage.
- Store and transport the device in its original packaging. Failure to do so makes the warranty void.
- Storage temperature: from -20°C to +60°C

Maintenance/cleaning

Spencer Italia S.r.l. disclaims any liability for any damage, direct or indirect, which is a result of improper use of the product and replacement parts and / or otherwise of any repairs made by an entity other than the authorized Spencer service centres; this will also invalidate the warranty.

- The operator must always wear adequate personal protection such as gloves and mask etc. during all checking, maintenance and cleaning procedures.
- Establish a maintenance program and periodic testing, identifying an employee responsible for overseeing. The person to whom the ordinary maintenance of the device is entrusted must ensure the basic requirements foreseen by the manufacturer in the user's manual.
- **The frequency of inspection is determined by factors such as legal requirements, the type of use, frequency of use, environmental conditions during use and storage.**
- Spencer Italia S.r.l. disclaims any liability for any damage, direct or indirect, that is the result of incorrect repairs or use of products made by Spencer Italia S.r.l. Repairs must necessarily be carried out by an authorized Spencer Italia service centre, which in using original spare parts will provide a quality repair service in strict accordance with the technical specifications given by the manufacturer. Spencer Italia S.r.l. disclaims any liability for any damage, direct or indirect, which is a result of improper use of spare parts and/or otherwise of any repairs made by an entity other than the Spencer service centres authorized to repair or make substitutions on this product and parts and/or otherwise of any repairs made by an entity other than the Spencer service centres authorized to do so; the warranty will also be invalidated.
- Use only original components, spare parts and or accessories, approved by Spencer Italia S.r.l., in order to carry out any operation without causing any alteration or modification to the device.
- For any operations that are not carried out directly by the manufacturer but by an authorised centre, we have to underline that a report regarding all operations carried out must be requested. This will permit both Spencer Italia S.r.l. and the end user to keep a log book regarding the operations carried out on the device.
- All maintenance and revision must be recorded and documented with the corresponding report for technical assistance; documentation shall be maintained for at least 10 years from the end of life and must be made available to the competent authorities and/or the manufacturer if requested.
- The cleaning schedule for reusable products must be performed in accordance with the directions provided by the manufacturer in the user manual, in order to avoid the risk of cross-infection due to the presence of secretions and/or residuals.
- The device and all its components, after washing, should be allowed to dry completely before storing.

Regulatory requirements

As a distributor or end user of products manufactured and/or marketed by Spencer Italia S.r.l., you are strictly required to have a basic knowledge of any legal requirements applying to the devices contained in this supply that are in power in the final destination Country (including laws and norms regarding technical specifications and/or safety requirements) of the goods and therefore you are also strictly required to have the necessary knowledge to guarantee all aspects regarding the total conformity of the products to the regulations in the relevant territory.

- Promptly notify Spencer Italia S.r.l. (already during the first product enquiry) when requesting in details regarding any revisions to be made by manufacturer in order to guarantee the conformity of the products to the territory's legal specifications (including those resulting from rules and/or norms of other kind).
- Act, with all due care and diligence, and contribute to ensure conformity to general safety requirements of all devices marketed in the territory, by providing final users with all necessary information for carrying out periodical checks on their devices, exactly as specified in the relevant user's manual.
- **Actively contribute to safety checks on product** sold, by communicating any relevant risk analysis information both to the manufacturer and to any competent authorities so that the necessary action can be promptly taken.
- The distributor or final user is aware that in the event of any failure to conform to the above mentioned requirements you will be deemed fully responsible for all damages that might occur. Therefore Spencer Italia S.r.l. expressly disclaims any responsibility and/or liability for your non-compliance with the present regulatory provisions.

General warnings for medical devices

The user must read carefully not only the general warnings, but also those listed below.

- It is not foreseen that the use of the device is prolonged beyond the time necessary for the first responders to complete their operation and the subsequent stages of transport to the nearest rescue point.
- When the device is being used, the assistance of qualified staff must be guaranteed and at least one operator must be present.
- Follow the procedures and protocols approved by the internal organization.
- The activities of disinfection and sterilization should be carried out in accordance with the parameters given in the validated cycle as specified in the technical standards.
- With reference to the D. Lgs. 24th February 1997, n. 46 emended by D. Lgs. 25/01/2010, n. 37 – Acknowledgement of Directive 93/42/CEE and 2007/47/CE concerning Medical Devices, we remind both public and private operators, that in the exercise of their activity detect an accident involving a medical product are required to notify the Ministry of Health, under the terms and in the manner established by the relative ministerial decrees and also to the manufacturer. Health care providers whether public or private are required to communicate to the manufacturer, any other inconvenience that may allow for the adoption of measures to ensure the protection and health of patients and users

6. SPECIFIC WARNINGS

For the use of S-MAX fastener, the user must have read, understood and follow carefully all the instructions described in this manual.

- Do not use if the device or any of its parts are damaged or excessively worn.
- Read the instruction manual of the stretcher being used. It is essential to have good knowledge of all movement procedures of the stretcher.
- Do not use the fastening system with devices that have not been approved by the manufacturer.
- Do not use drying machines.
- Before each use always check the integrity of the device, as specified in the owner's manual. In case of faults or damages that may impair the functionality and the safety of the device, suspend the service and contact the manufacturer.
- Do not alter or modify arbitrarily the device: this modification may lead to unpredictable operation and injury to the patient or to the users and it will make the warranty void lifting the manufacturer from any responsibility.
- When securing the stretcher, make sure that nothing interferes with the locking systems. Inobservance of this warning may lead to an unsafe fixation and/or crushing injuries..
- The S-MAX fastener complies with the requirements of the EN 1789 standard only if used with Spencer 10G stretchers and if installed on surfaces capable to withstand forces described in such standard.
- Before installing make sure that the emergency vehicle meets all requirements
- The installation must be carried out in accordance with the instructions given by the manufacturer
- Do not remove the stretcher from the fastener when the vehicle is in movement
- Make sure that the locking system is always properly and fully inserted and that the stretcher is properly positioned on the fastener.
- Make sure there are no foreign bodies between the stretcher and the fastener.
- Check tightness of screws as required by this manual.
- When you place the stretcher on the fastening system, pay attention to the positioning of the hands. Incorrect positioning may cause serious injury.

6.1 PHYSICAL REQUIREMENTS OF OPERATORS

The fixing system S-MAX is a device intended for professional use. All operators must be trained to a safe and efficient use. Do not allow people who have not been trained to help during product use, as this may cause injury to yourself or others.

Users must be able to safely handle the Spencer stretcher in use, so as to ensure the safe coupling with the fastening system.

Installers should be able to install the equipment as prescribed by the manufacturer ensuring the suitability of supporting surface.

The ability of each operator should be evaluated before the definition of the roles of the operators in the use of the device.

7. RESIDUAL RISK

The residual risks listed below have been identified exclusively in reference to the intended use of the device.

- Use by untrained personnel, may result in injury to the patient, the rescuer and third parties.
- Inadequate disinfection procedures, can result in some degree of cross-infection.
- Intervention on the device by anyone who has not undergone training, can cause the deactivation of the lock system with consequent risks for all occupants of the vehicle. Make sure that no unauthorized intervention of any kind is done on the device.
- The use of S-MAX with devices not approved by the manufacturer, does not guarantee their proper fixing with consequent risks for patient and operators.
- Failure to observe warnings for operators, can result in the serious injuries caused by actioning mechanisms.
- **Failure to read and understand the instructions of the Spencer stretcher being used and the S-MAX fastener can have serious consequences for patient and operator.**

8. TECHNICAL DATA AND COMPONENTS

Note: Spencer Italia S.r.l. reserves the right to make changes to specifications without prior notice.

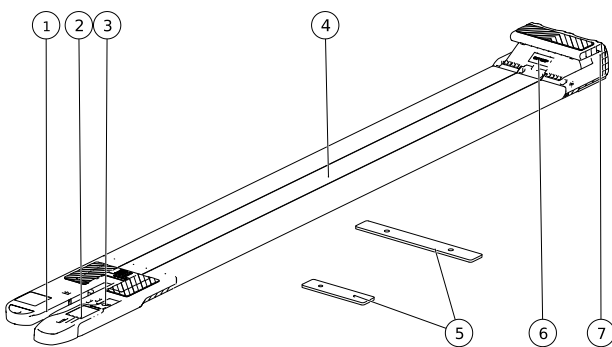

N°	Description	Material
1	Fifth wheel insertion area	-
2	Stretcher release lever	Nylon
3	Stretcher release lever for Sharp system	Nylon
4	Metal profile	Al
5	Fixing counter plates	Galvanized steel
6	Locking flap	Nylon
7	Front anchor	Nylon

Characteristics	
Dimensions (mm)	1790x190x80 ± 5mm
Metal profile thickness	30 mm
Weight ^(without counter plates)	5,2 ± 0,1 kg

9. START UP

Before the first use verify that:

- The packaging is intact and has protected the device during transport
- Check that are present all the components included in the accompanying list.
- Functionality of the device according to the user manual
- The ambulance has installation surfaces capable to ensure compliance with EN 1789 requirements, and allowing an installation that does not compromise the access to other devices.
- The installation has been carried out like described in this manual and the functionality of the product has been fully verified.

Do not modify for any reason any part or component of the fastener as this may cause injury to the patient and/or rescuers.



If conditions mentioned above are not satisfied, the device cannot be considered secure, safe use is compromised and it is a possible cause of injury for patient and operators and can cause damage to the device.

It is recommended to practice with the device in non-operating conditions before the regular start-up.

For instructions on use after start-up, follow the operations described on paragraph 12.

If the above conditions are met, the device may be considered ready for use; otherwise you must immediately remove the device from service and contact the manufacturer.

Do not alter or modify in any way the appliance; any such interference could cause malfunctions and injury to the patient and/or rescuer. Moreover the manufacturer will no longer recognize the product warranty and will accept no responsibility.

10. FUNCTIONAL CHARACTERISTICS

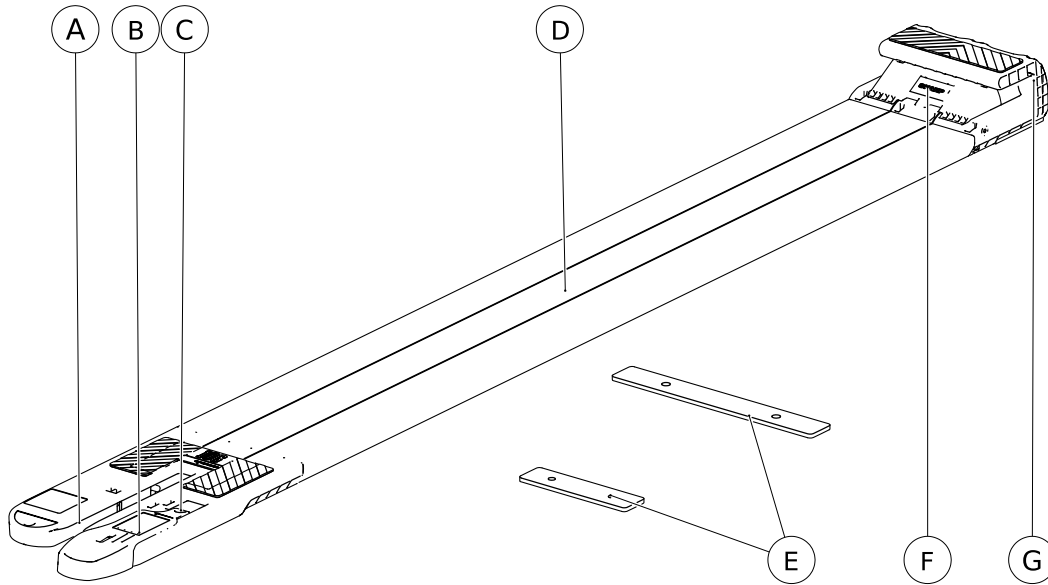

Element	Description	Function
A	Fifth wheel insertion area	Required for the coupling with the fifth wheel of the stretcher
B	Stretcher release lever	Used to release the stretcher from the fastener
C	Stretcher release lever for Sharp system	Area of the release lever used only if the stretcher is equipped with Sharp release system
D	Metal profile	Connection component between front and rear part of the fastener
E	Fixing counter plates	Supplied with the fastener, they must be used for the installation of the device, placing them under the installation surface
F	Locking flap	Allows to lock and unlock the stretcher
G	Front anchor	Component of the fastener that secures the stretcher in position acting on its front part

11. INSTRUCTIONS FOR USE

11.1 Medical vehicle requirements

The fastener S-MAX is designed for installation inside an ambulance.

For its installation, the emergency vehicle must be equipped with suitable surface to hold the fastener and the stretcher safely in position.

The vehicle must therefore meet the following essential requirements:

- Loading platform sufficiently big to contain without creating obstacles the anchoring system with the stretcher.
- The fixing platform must be perfectly horizontal and completely flat
- Installation surfaces capable to withstand forces like described in the standard EN 1789, considering the stretcher being used and its maximum loading capacity..



Failure to comply with these requirements or incorrect installation can endanger the safety of patients and operators

11.2 Installation

For proper installation of the fastener, it is fundamental that the floor is perfectly horizontal. The surface on which the device is installed, must be perfectly flat both in the fixing and supporting areas. Failure to comply with these specifications may result in an alteration of the geometry of the device resulting in non-compliance of the device with its original design specifications.

The structure of the fastener is equipped with 8 holes required for installation; 4 for the front part and 4 for the rear one.

The rear part of the fastener has two pairs of slots which can be accessed by temporarily removing the access covers. For the installation is sufficient to use only a pair of such slots, but they must be chosen symmetrical with respect to the longitudinal axis of the fastener. It is necessary to choose which slots will be used for the installation before drilling.

Use the fastener as a drilling template of the surface on which the device has to be installed, positioning it parallel to direction of movement of the vehicle.

For the front part, use the four holes at the corners of the front anchor..

The following table shows details of screws to be used:

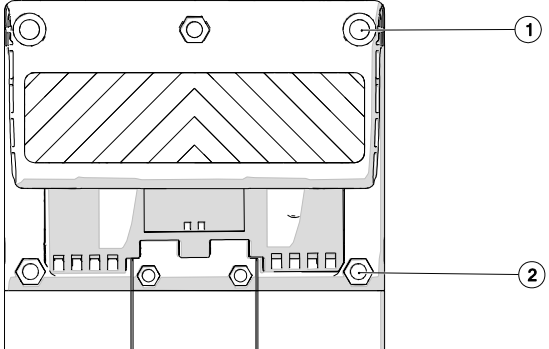
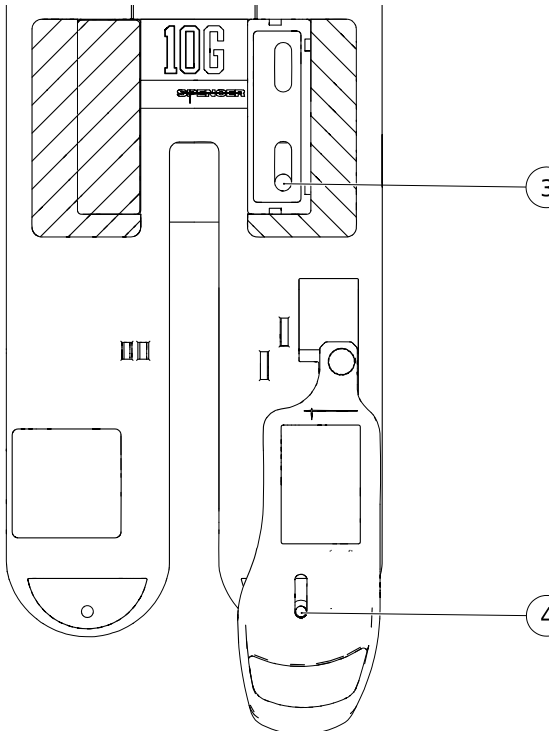
TAB. 1	ID	Bolt	Resistance Class
	1	TCEI 10 x (80 + installation surface thickness)	10.9
	2	TCEI 8 x (30 + installation surface thickness)	8.8
	3	TCEI 8 x (20 + installation surface thickness)	8.8
	4	TPSEI 5 x (30 + installation surface thickness) Note: Left and right side could require different lengths	8.8

! Before drilling, you must ensure that no part, component or device in the vehicle is compromised during this phase. Be particularly careful to ensure the integrity and the possibility of maintenance on circuits and electrical components, structural and any gas pipes. If the device is installed on a loading platform, the installation must consider also the increased dimensions caused by the use of accessories like front adapters installed on the stretcher, so that the loading trolley wheel do not protrude from the loading platform.

! S-MAX is provided with two counter-plates to be used for the installation and to be used both on the front and rear part. The safety and functionality of the device can be seriously compromised if such counter-plates are not used.

After the drilling has been performed, install the device using bolts having suitable length in relation to the thickness of the installation surface according to the specifications of TAB. 1.

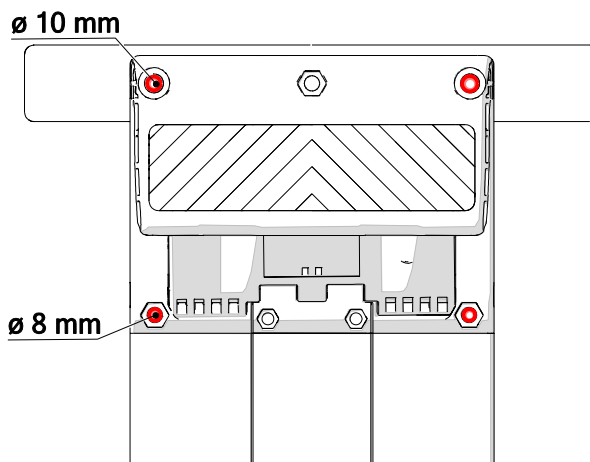

11.3 Use of the fastener

- Load the stretcher on the loading platform.
- Push the stretcher against the front anchor making sure that the fifth wheel of the stretcher is correctly inserted inside the seat on the back side of the fastener.

- To release the stretcher from the fastener, pull the red release lever as shown in the picture until it is possible to feel a slight movement of the stretcher.

- Terminate the release of the stretcher pulling it out from the vehicle only after the unlocking lever has been released. Keeping hands in the vicinity of the lever could lead to crushing injuries.

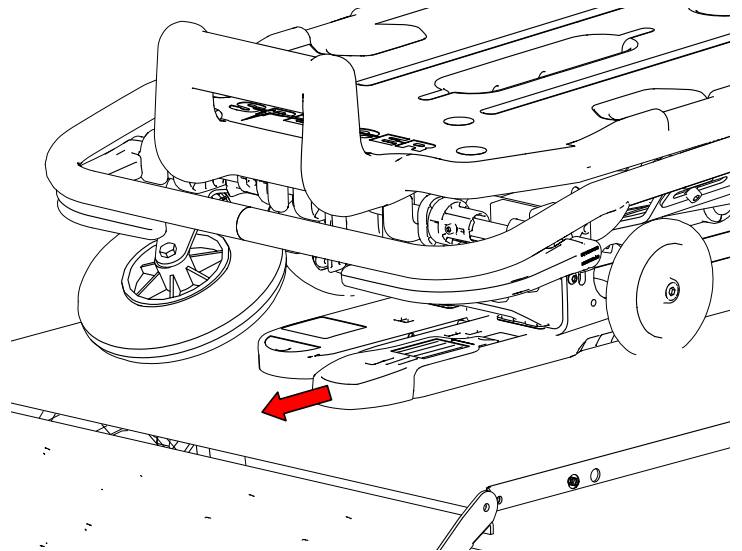

Warning: After the stretcher has been unlocked, in order to ensure a safe unload from the ambulance, it is necessary to grab the main frame of the stretcher with both hands.

12. CLEANING AND MAINTENANCE

12.1 CLEANING

Failure to carry out the correct cleaning routine could increase the risk of cross infection, due to presence of body fluids and/or residuals.

The operator must always wear adequate personal protection such as gloves and mask, etc. during all checking and cleaning procedures.

The exposed metal parts are usually treated and/or painted in order to increase their resistance to external agents. Clean the exposed parts with water and a delicate soap; **never use solvents or stain removers.**

Rinse thoroughly with warm water making sure that you have removed all traces of detergent, which could ruin or compromise the integrity and durability of the device. **The use of high pressure water should be avoided** because water penetrates in the joints removing the lubricant and creating the risk of corrosion of components. Allow the device to dry thoroughly before storing. Drying after washing or after use in wet environments must be natural and not forced; do not use flames or other sources of direct heat.

If the device needs to be **disinfected**, use products that do not have corrosive or solvent action on the materials of which the device is made. Be sure to take every precaution to ensure that there is no risk of cross-infection or contamination for patients and / or operators.

12.2 PRECAUTIONARY MAINTENANCE

Establish a maintenance programme and periodic testing routine and identify an employee responsible for this. The person to whom the ordinary maintenance of the device is entrusted must ensure that the basic requirements foreseen by the manufacturer in following paragraphs are inspected.

All maintenance and periodic servicing activities must be registered and kept together with the servicing reports. These documents have to be kept for a period of 10 years after the disposal of the device itself. This register will be made available to the competent authorities and/or manufacturer if requested.

Routine maintenance of the device must be carried out by operators in possession of specific qualifications, trained and experienced in the use and maintenance of the device.

The operator must always wear adequate personal protection such as gloves and mask, etc. during all checking and cleaning procedures.

Checks to be carried out before and after each use and at deadline indicated above, are as follows:

- General functionality of the device
- Cleanliness of the device (remember that the failure to clean could be the cause of cross infections)
- Correct fixation of all nuts, bolts and screws
- Absence of cuts, holes, tears on the structure, including the straps
- None of the tubes or metal sheets present bends or cracks
- Verification of the functionality of the release system. By activating the release lever (or the Sharp system installed on the stretcher), the front flap should reach the horizontal position allowing the stretcher release. Once the release lever has been released, the flap should return quickly in its original position pushing against the upper side of the front anchor.
- Check that the coupling between the stretcher and the fastener is stable and safe.

The inspection frequency is determined by factors such as local legal requirements, the type of use, frequency of use, environmental conditions during use and storage.

The device doesn't need lubrication in any component or mechanism.

Please note that you need to clean the filter described in this manual and checking the features before and after each use. Spencer Italy S.r.l. declines any responsibility for malfunction or damage caused to the patient or operator from using devices not subject to routine maintenance will void the warranty and whereby the 93/42/EEC directive medical devices..

Use only components/spare parts and/or accessories original or approved by Spencer Italy S.r.l., in order to carry out any operation without causing alteration, modification to the device; otherwise we decline all responsibility for malfunction or damage caused by the device to the patient or operator will void the warranty and whereby the 93/42/EEC directive medical devices.

12.3 PERIODIC MAINTENANCE

The device must be serviced by the manufacturer or by an authorised centre, every year.

If the correct revision is not carried out, the device **MUST BE PUT OUT OF SERVICE**, because the CE branding will no longer be considered valid and consequently it is no longer compliant with the safety standards declared by the manufacturer at time of purchase.

Spencer Italia S.r.l. will take no responsibility for the incorrect functioning or any damage caused by a device that has not undergone regular revision.

For any operations that are not carried out directly by the manufacturer but by an authorised centre, we have to underline that a report regarding all operations carried out must be requested. This will permit both Spencer Italia S.r.l. and the end user to keep a log book regarding the operations carried out on the device.

12.4 SPECIAL SERVICING

Only the manufacturer or centres with written authorisation are authorised to complete any special servicing operations.

For any operations that are not carried out directly by the manufacturer but by an authorised centre, we have to underline that a report regarding all operations carried out must be requested. This will permit both Spencer Italia S.r.l. and the end user to keep a log book regarding the operations carried out on the device.

The end user is authorised to replace only the spare parts indicated in the paragraph 15.

12.5 LIFE SPAN

The device, if used as indicated in the following instruction manual, has a life span of 5 years starting from the purchase date. The life span can be extended following the annual revision.

General revisions must be carried out by the manufacturer or by a centre authorised by the manufacture. **If such annual revisions are not carried out, the device MUST BE DISPOSED ACCORDING TO THE PROCEDURES SPECIFIED IN PARAGRAPH 16 AND THIS EVENT MUST BE NOTIFIED TO THE MANUFACTURER.**

The life span can be extended, by unquestionable judgment of Spencer or authorized service center, if the safety requirements of the device are still guaranteed.

Spencer Italia S.r.l. will accept no responsibility for the incorrect functioning and/or damage caused by the use of any device which has not been serviced by the manufacturer or authorized center, or of any device for which the life span is expired.

13. TROUBLESHOOTING

PROBLEM	CAUSE	SOLUTION
The device is installed, but the base is not fully or correctly positioned on the installation surface.	The device has not been properly installed	Verify that the drilling has been properly carried out, that the fastener has been used as drilling template and that during installation no deformation of any kind has occurred.
	The contact surfaces do not meet the requirements of the manufacturer	Verify that the installation surfaces are flat
The base or other elements of the fastener are damaged	The components were damaged during installation	Put the device immediately out of service and contact the service center
	The tear and wear caused by use have caused damage to parts	
The release lever does not show any resistance to the translation and doesn't return in its original place	The spring inside the locking system is damaged	Put the device immediately out of service and contact the service center
	The release lever is damaged	
Is not possible to fix the stretcher on the fastener	The stretcher being used is not suitable for the fastener	Contact the manufacturer or the service center to check the compatibility of the device
	The stretcher has not been correctly inserted into the fixing system	Check the correct insertion of the stretcher. For a correct mounting, the stretcher must be perfectly aligned with the fastener
The Stretcher and the hook assembled together do not seem to be stable	The fixing screws are loosened or the contact surfaces are deteriorated and generate looseness	Put the device immediately out of service and contact the service center

14. ACCESSORIES

There are no accessories for this device

15. SPARE PARTS

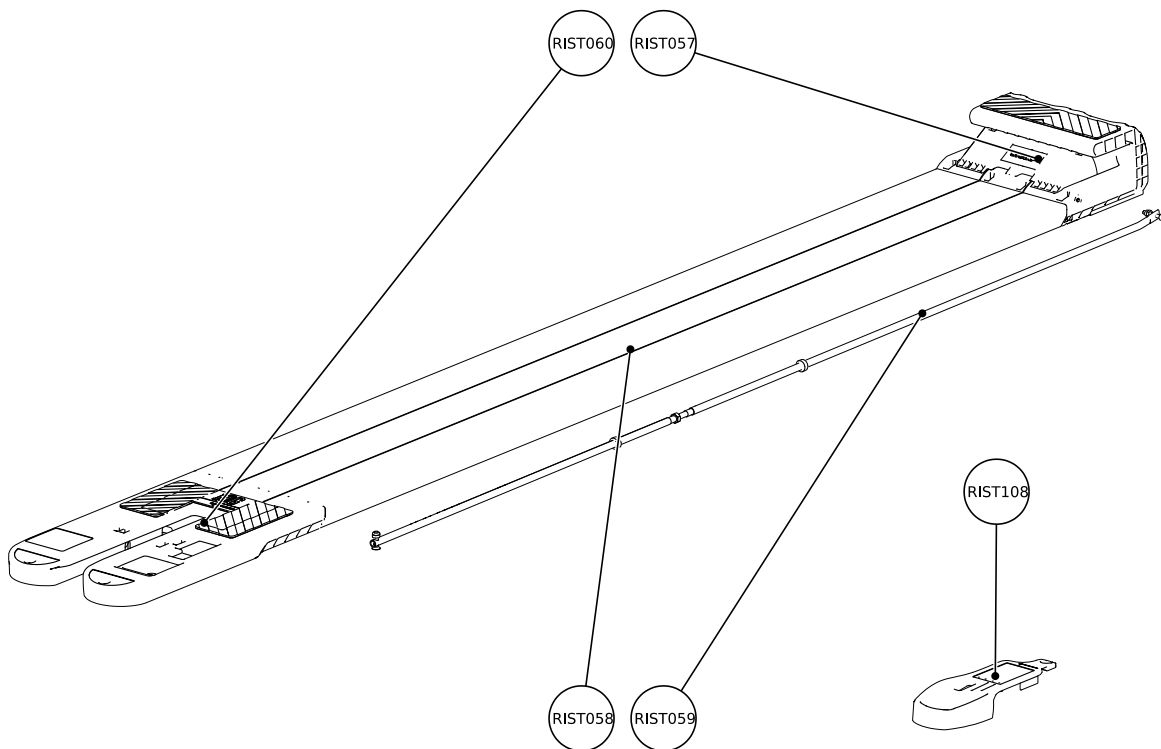

16. DISPOSAL

When the device is no longer suitable for use, if they haven't been contaminated by any particular agents, they can be disposed of as normal solid waste. Otherwise follow the current regulations for demolition.