

PROMYGES

Field stretcher

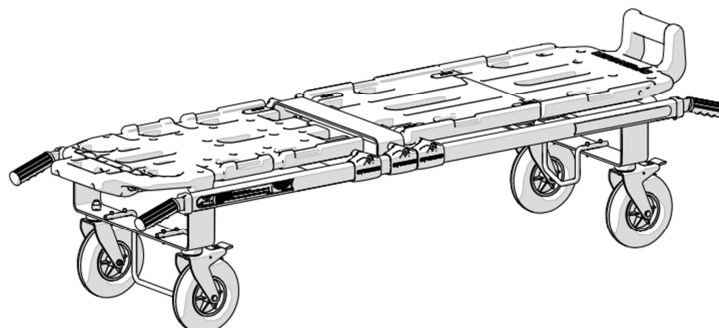

PRIME series stretchers PROMYGES are devices for lifting and carrying people for use in field rescue situations. Parking is permitted preferably when using the parking stops installed in designated locations within the rescue area.

Specific features

- The stretcher can be locked both in front and rear part using the dedicated fasteners
- Polyethylene patient board easy to clean
- Adjustable backrest
- Front and rear telescopic handles
- Wheels have large diameter to increase sliding action
- Brakes on outer wheels to stabilize the device when the vehicle is in motion
- Soft mattress to increase patient comfort
- Included belts with plastic hook for restrain the patient
- Large diameter wheels to increase sliding action

Standard equipment

- PVC Anatomic mattress
- Restraint belts (2 pcs)

Accessories

- ST42100 – Rear fastener for stretchers
- ST42714 – Front fastener for stretchers

Technical data

| | |
|---------------------------|--------------------------------------|
| Stretcher length | 1820 mm |
| Stretcher width | 575 mm |
| Possible anchorage points | 2 with Front and rear stop accessory |
| Materials | Al, PE, Nylon, Steel |
| Weight | 16 ± 3 kg |

Class I MD compliant with UE Reg. 2017/745

MOD.P028 STRETCHER
ST00028



Rev.0 (03/08/2021)

UNCHECKED COPY – further revisions will be available on <http://support.spencer.it>
Spencer Italia S.r.l. Sala Baganza (PR) Italia Tel. +39.0521.541111 Fax +39.0521.541222

www.spencer.it